

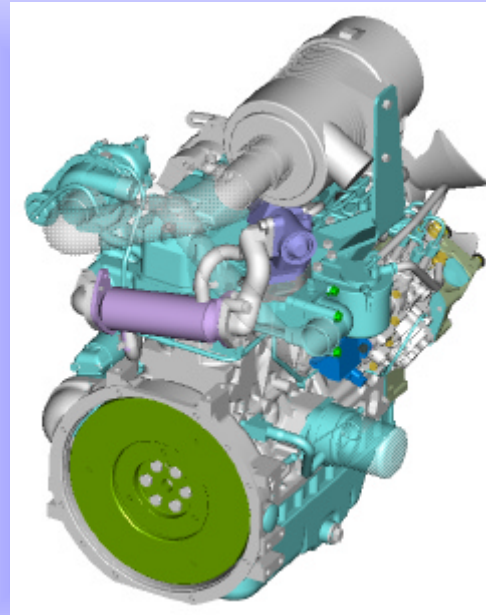

YANMAR

TNV TIER3 INTRODUCTION





YANMAR

TNV Tier 3 Technology

ECO governor system operation

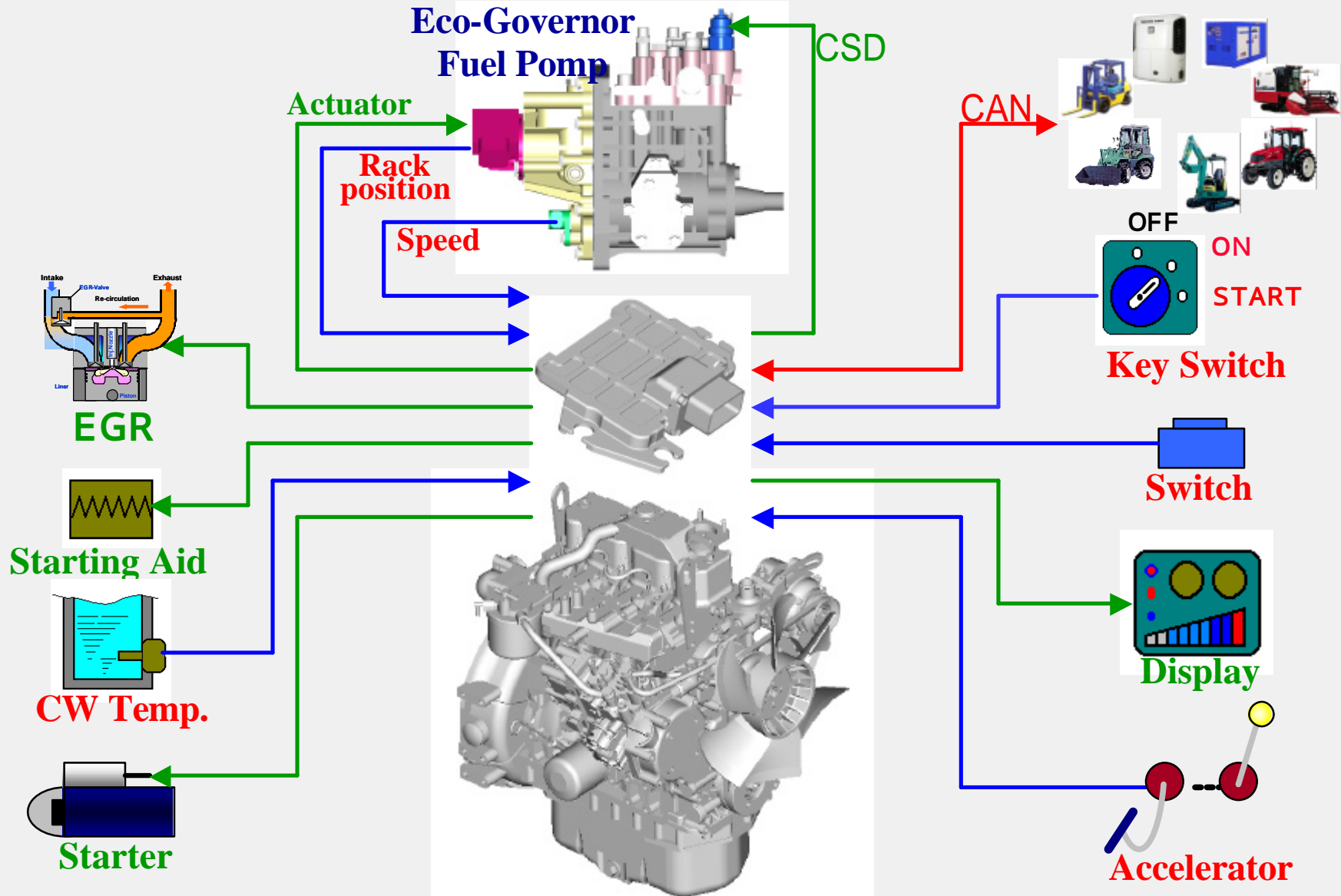



YANMAR

TNV Tier 3 Technology

ECO governor
system operation

NOx Reduce Measure

=EGR (Exhaust Gas Recirculation)=

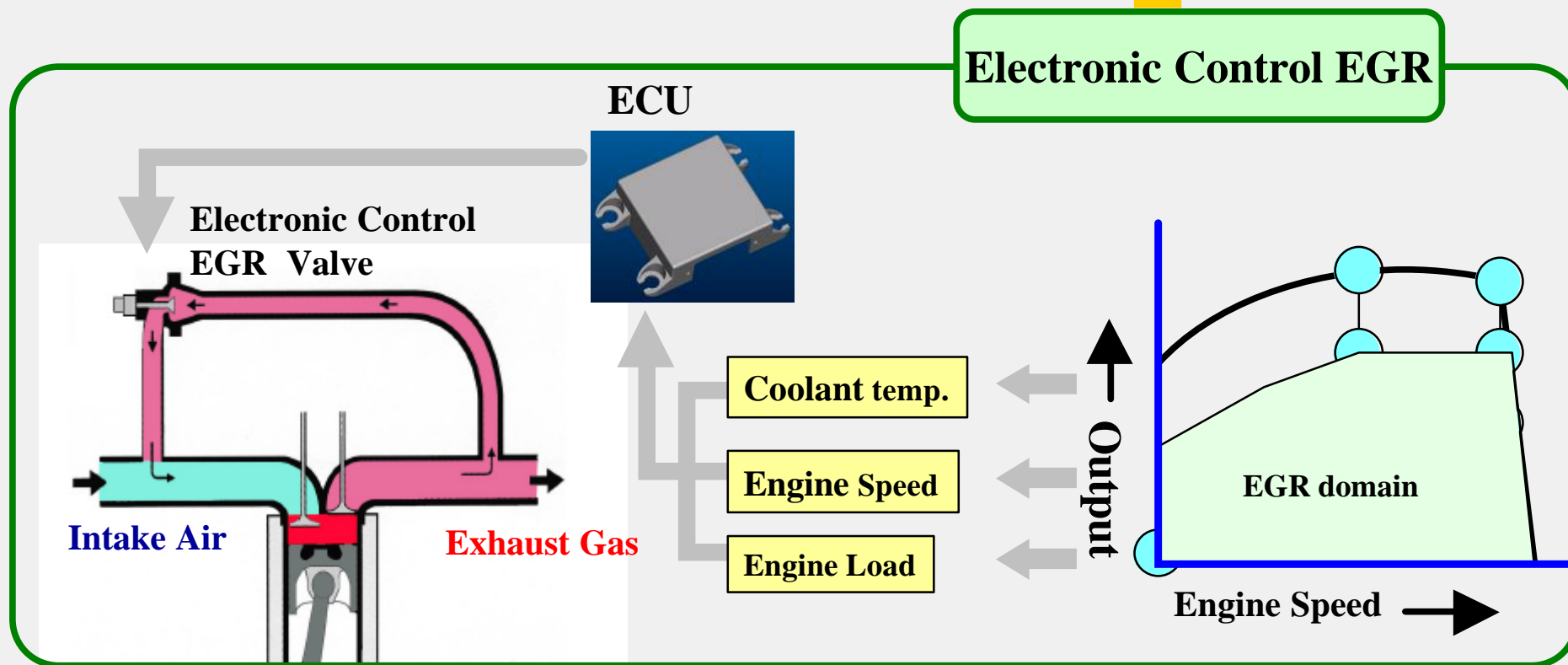
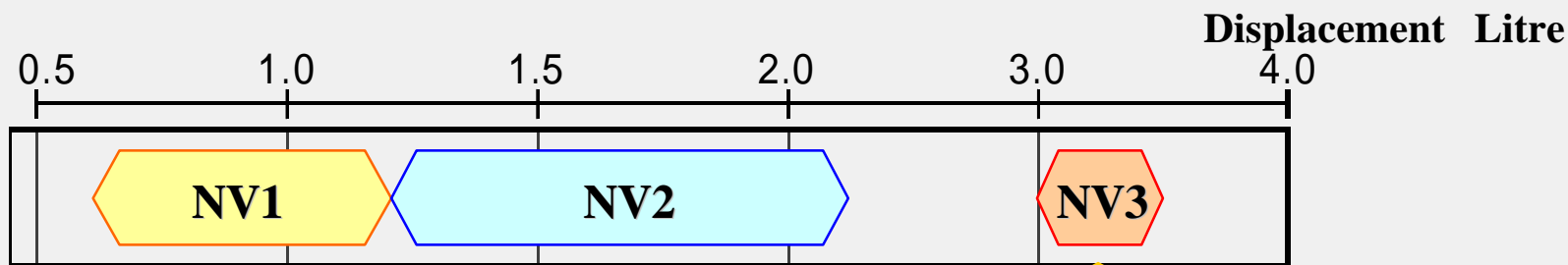



YANMAR

TNV Tier 3 Technology

ECO governor
system operation

EGR valve

EGR valve is operated by step motor.

Valve opens with 54 steps and is controlled pending on engine speed and load factor (=determined as percentage from rack position @ idl, max, min and Ract (relative to Rmin) .

Load factor is delivered as PWM signal from the E-ECU.

Below 60 °C EGR valve will not be opened.

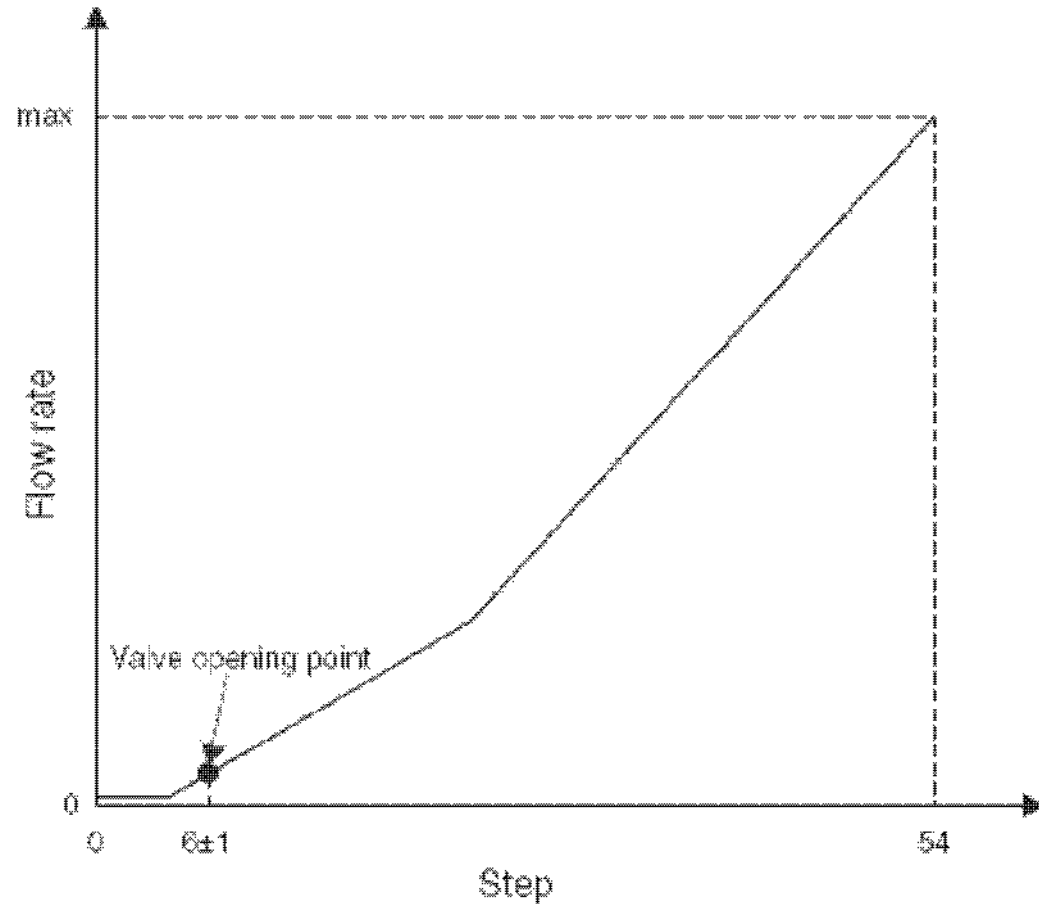

Fig. 2-31 EGR Valve Characteristics



YANMAR

TNV Tier 3 Technology

ECO governor
system operation

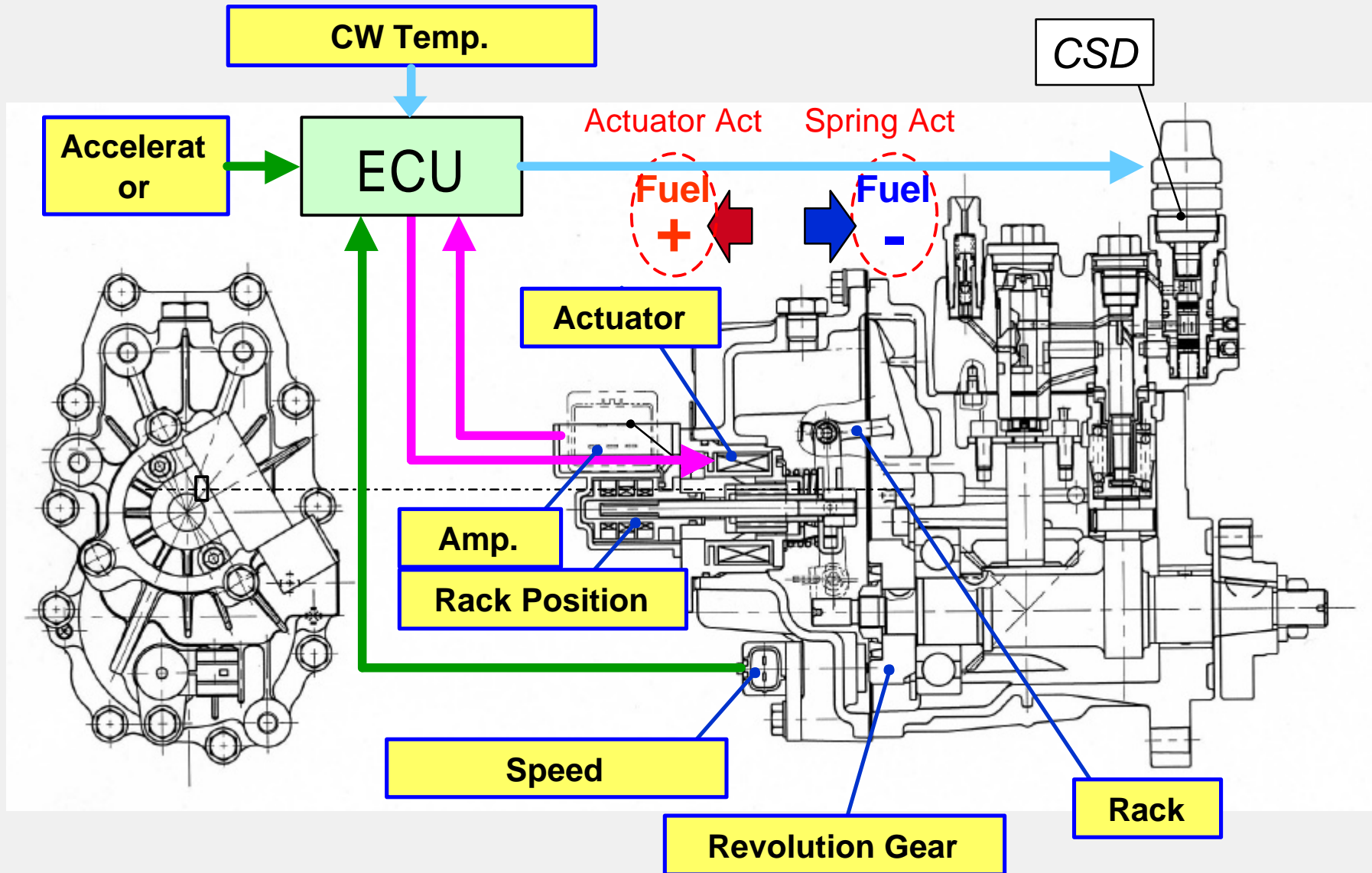





YANMAR

TNV Tier 3 Technology

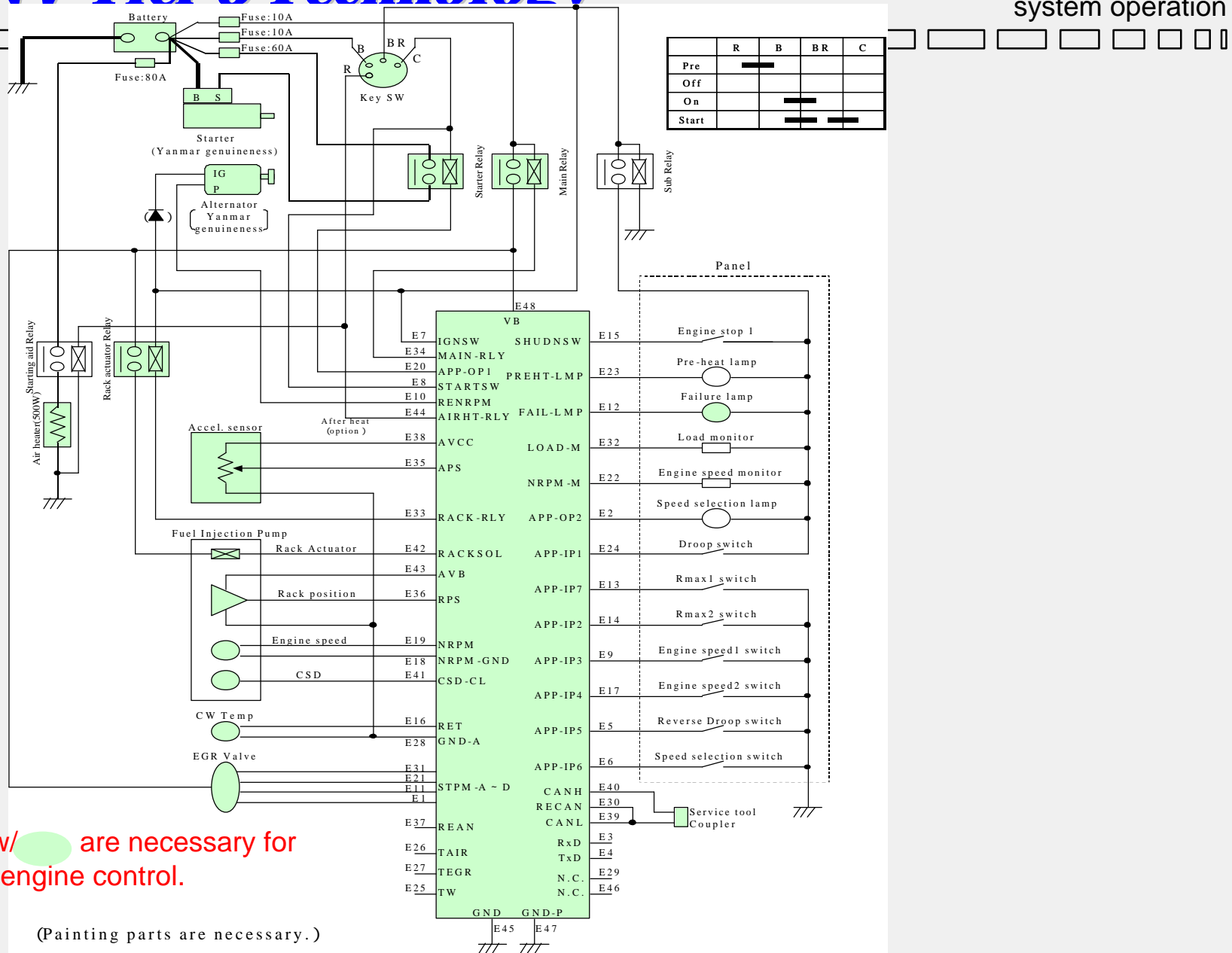
ECO governor system operation



Marked w/  are necessary for engine control.

(Painting parts are necessary.)



YANMAR

TNV Tier 3 Technology

(dis)advantages
NEW technology



Torque curve regulation

Selective Governor Mode

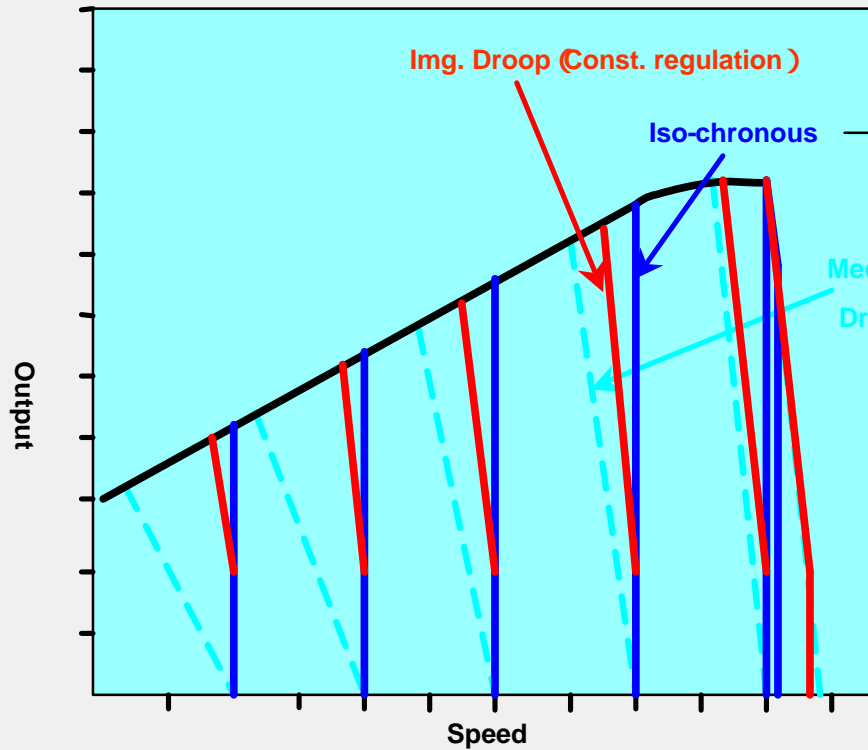

Regulation is 0% on the speed (constant)

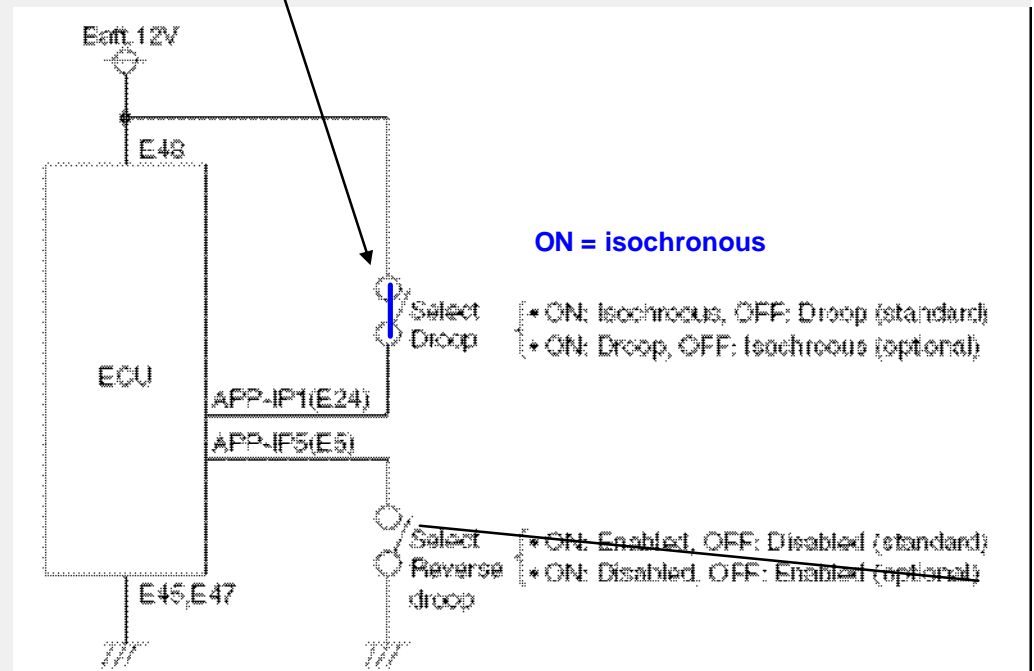



YANMAR

TNV Tier 3 Technology

(dis)advantages
NEW technology



Torque curve regulation

Selective Governor Mode

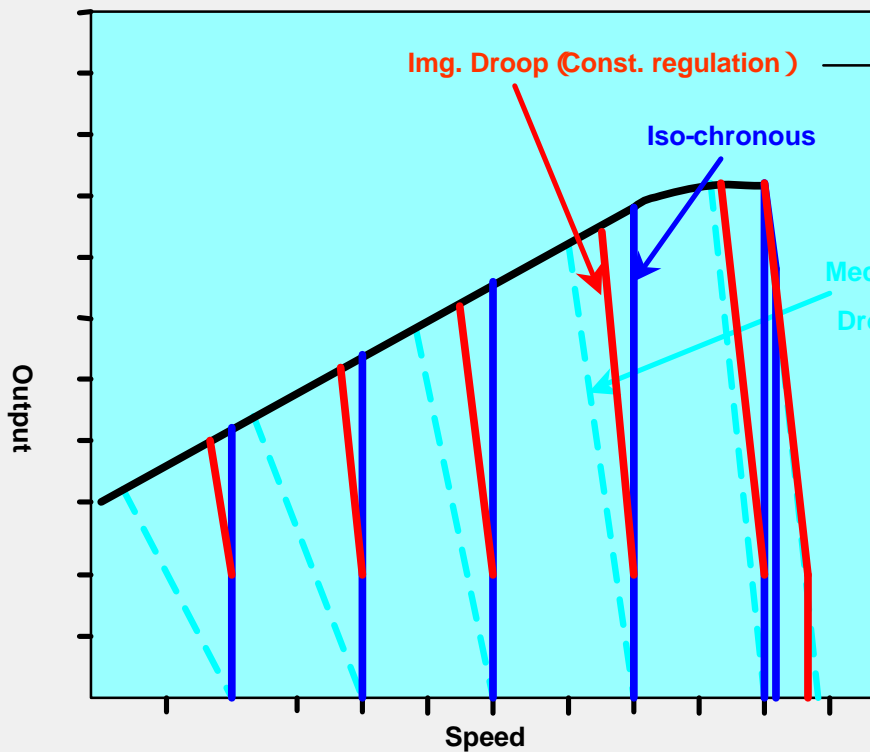

Regulation is approx. 7% (=standard)

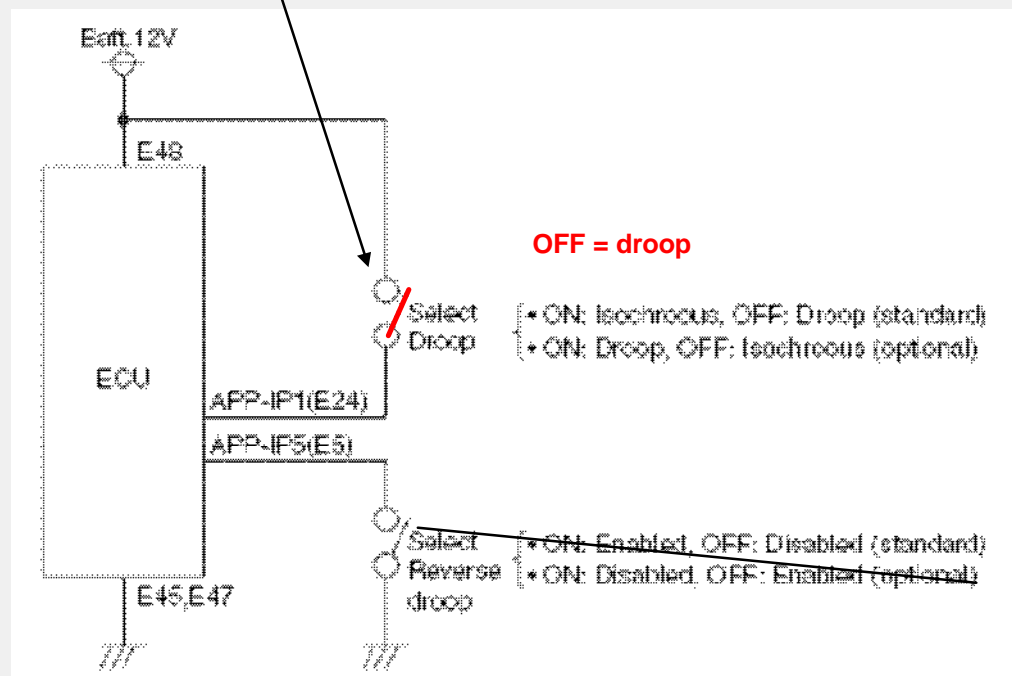

OFF = droop

- ON: Isochronous, OFF: Droop (standard)
- ON: Droop, OFF: Isochronous (optional)

- ON: Enabled, OFF: Disabled (standard)
- ON: Disabled, OFF: Enabled (optional)



YANMAR

TNV Tier 3 Technology

ECO governor
system operation

Transition control
(avoid spill of fuel)

ECU Engine Speed Control

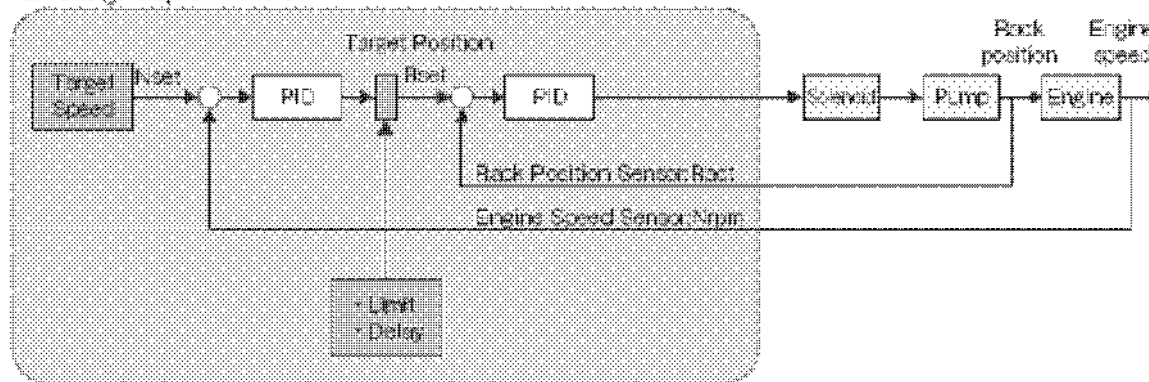
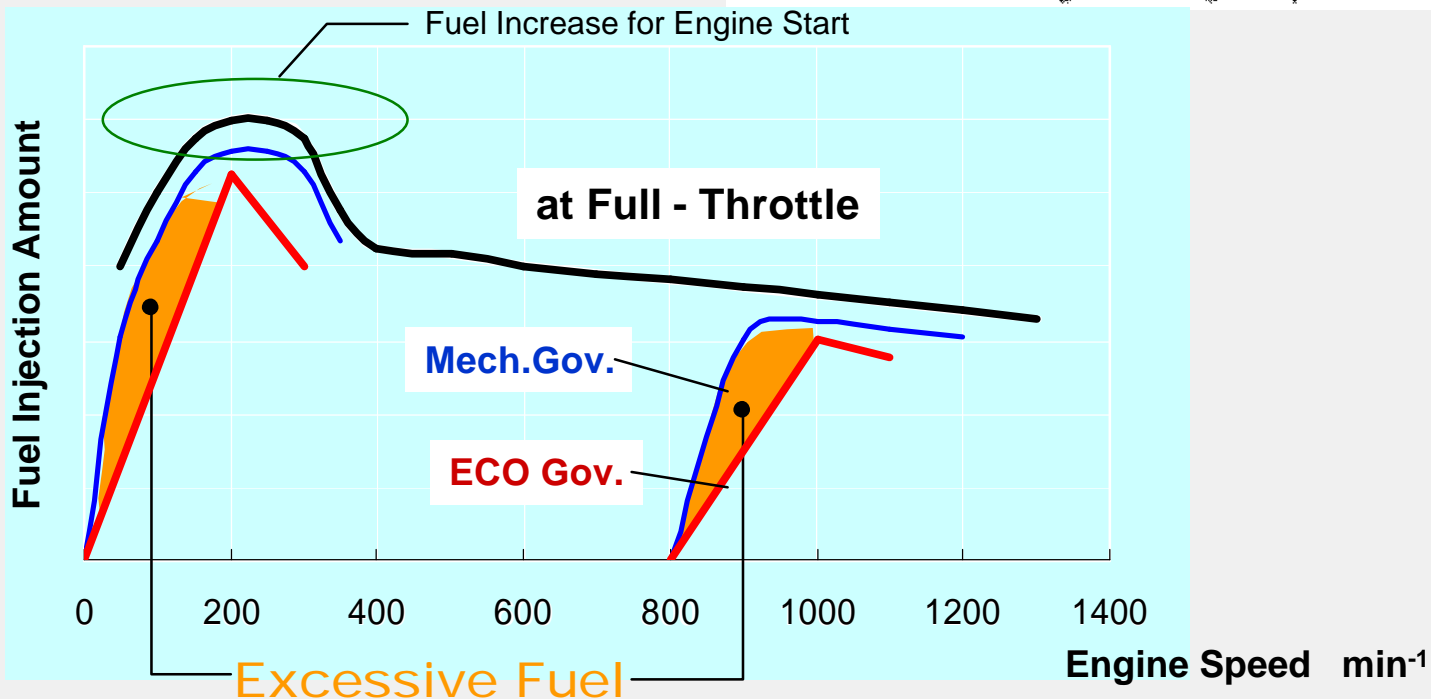

Fig. 2-29 Engine Speed Control Block Diagram





YANMAR

TNV Tier 3 Technology

ECO governor
system operation



Starter control

Complete Rack Self Test

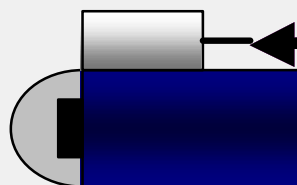
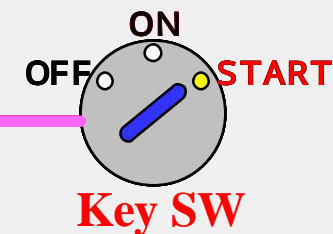
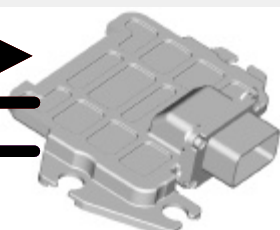
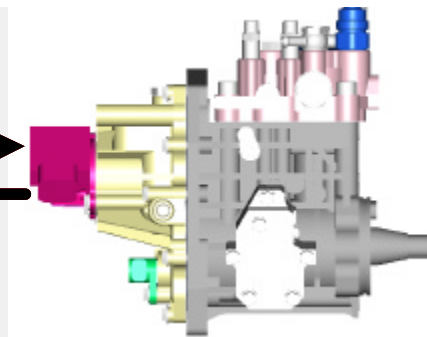

Starter

Complete Engine Start

Starter Control

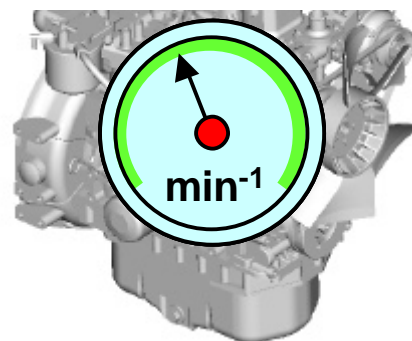

Starting Aid Control (Standard)



YANMAR

TNV Tier 3 Technology

ECO governor system operation



Engine SHDW

Speed Control Function

Speed Control / speed selection



Immobilizer **Emergency STOP**



Turn.Back Deceleration **Auto/One Touch Deceleration** **Const. Speed**

External SW Setting (CAN Sig. Compatible only NO type = terminal E13)

Emg. Stop	Speed Enable SW	Speed 1 SW	Speed 2 SW	Speed Control
off	-	-	-	Engine STOP
on	off	-	-	Accelerator
	on	off	off	Deceleration 1
		on	off	Deceleration 2
	on	on	off	on
on			on	Const. Speed 2

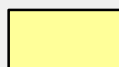
 :Option

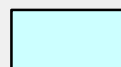
 :Generator Standard



YANMAR

TNV Tier 3 Technology

ECO governor
system operation

Low (up) / High (down) idle-Speed Control (option)

Cold State

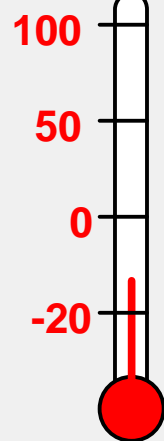

WO Temp.



100

50

0

-20



WO Temp.

**Shorten
Warm up**

**Reduce
White Smoke**

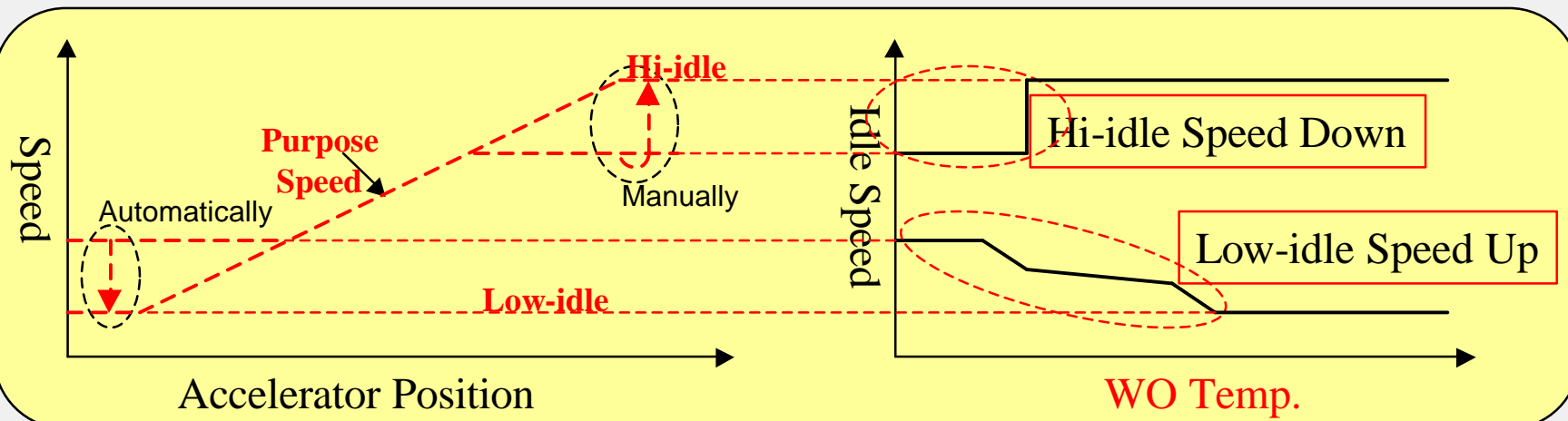
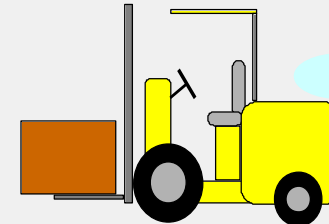



YANMAR

TNV Tier 3 Technology

ECO governor
system operation

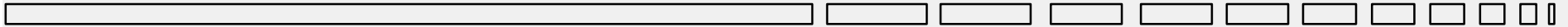

Starting Aid Control (Standard)

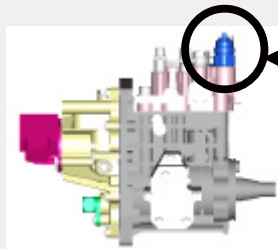

CSD

After Heat (option)
($t=80$ sor CW Temp 10)



Reduce White Smoke



Lamp

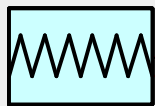

Air Heater

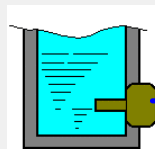

CW Temp.

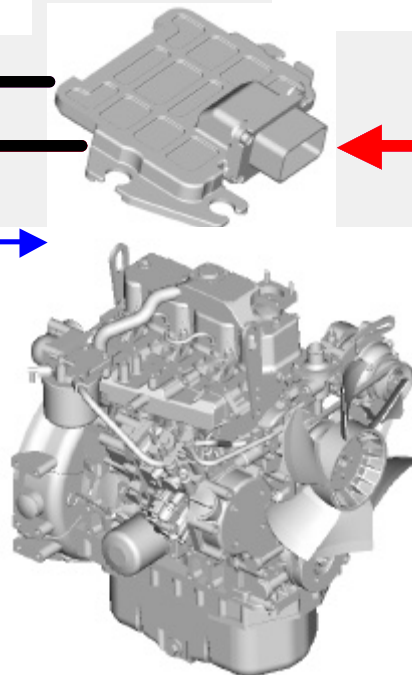

Engine Start Complete



Key SW



TNV Tier 3 Technology

Service tool and diagnostics

1

All the data including injection quantity is stored in Product Data Management(PDM) before shipping, therefore when replacing FOP, new compensation data shall be re-stored in PDM.

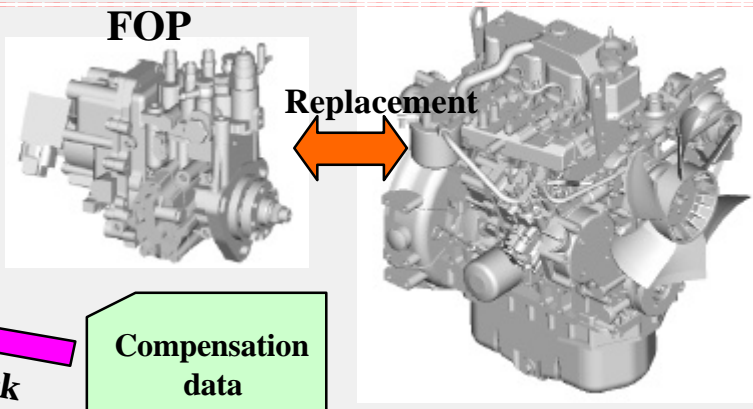
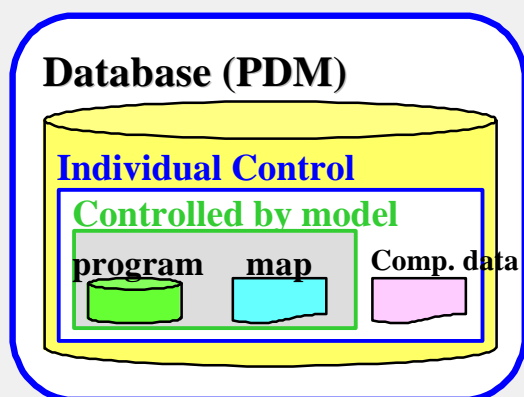

2

Download

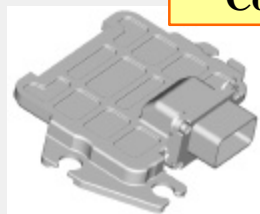

Control program
Map
Compensation data

Blank
ECU

When replacing ECU with new one in the field, the data shall be transferred from old one to new one or download the data for applicable engine serial number.



TNV Tier 3 Technology

Function of Service tool

Diagnosis Tool
(Yanmar's unique tool)

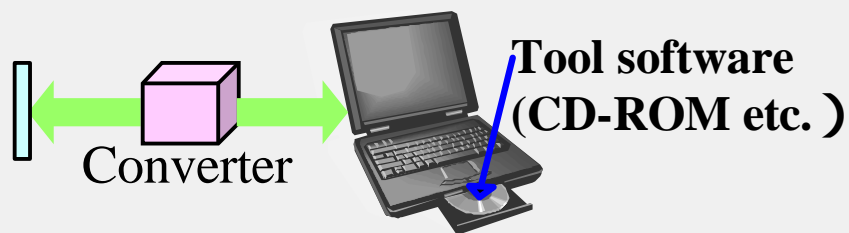

Microsoft Windows
PC (2000/XP)

Adoption of KWP 2000
Keyword Protocol 2000

【diagnosis】

- Monitor display
- Error code display
- Test for diagnosis
- Data logging

- Special signal converter is required.
- Software can be distributed by CD-ROM and the Internet.



YANMAR

TNV Tier 3 Technology

Service tool and diagnostics

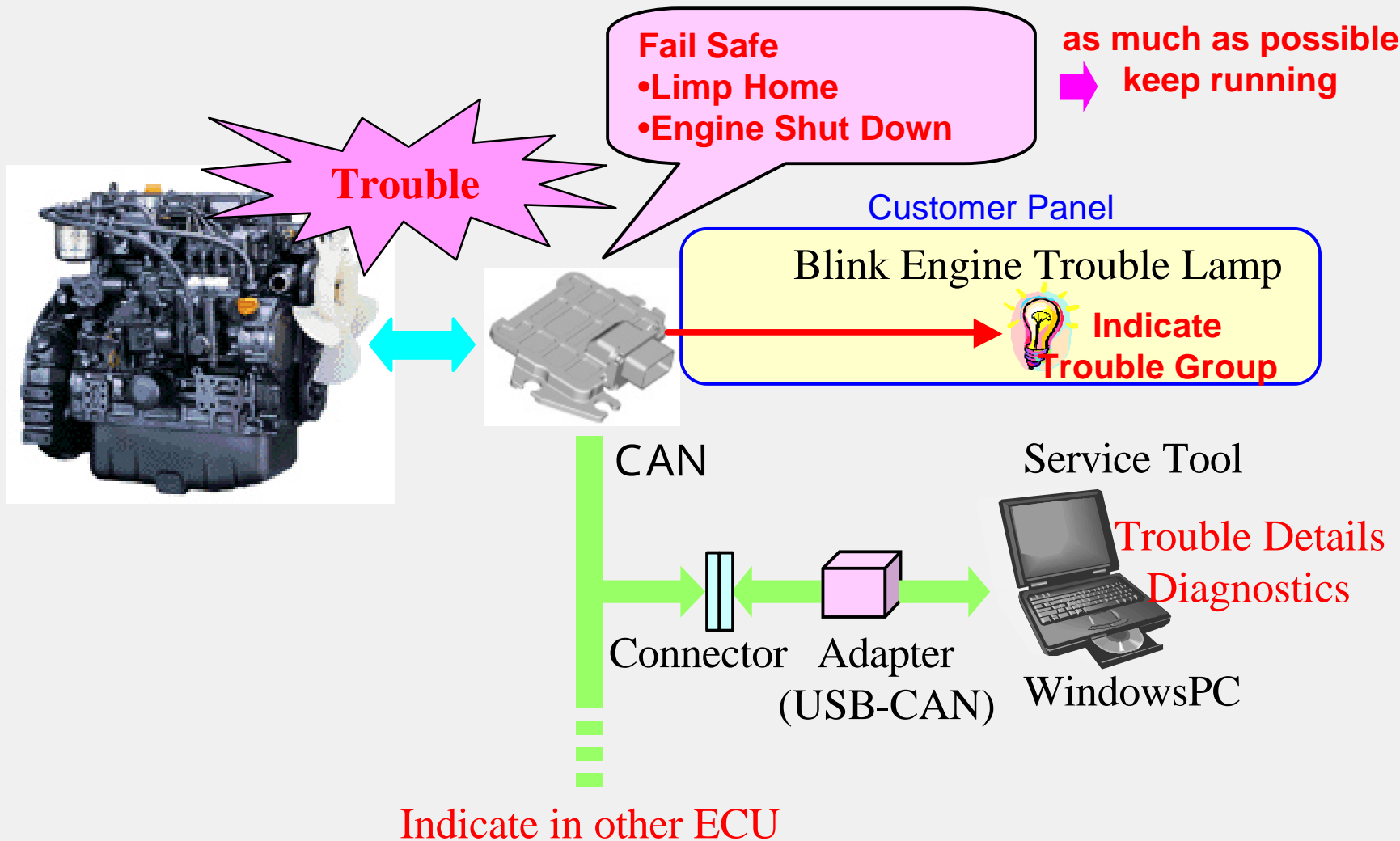
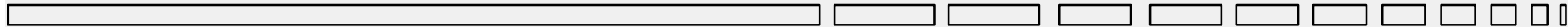



YANMAR

TNV Tier 3 Technology

Service tool and diagnostics

Customer Panel

Blink Engine Trouble Lamp

Service tool



Indicate Trouble Group

No.	Item	Failure Detection Condition	Operation When Failure Occurs	Action/Condition for Recovery	Setting	Number of Flashes
1	Coolant temperature sensor failure	Sensor voltage is 4.6 V or more, or 0.2 V or less.	<ul style="list-style-type: none"> Engine continues to run with a coolant temperature of 30°C. Engine runs with the same limitations as in the case of EGR valve failure. 	Correct failure.	Always enable	4
2	Accelerator sensor failure	Sensor voltage is 4.6 V or more, or 0.2 V or less.	<p>[Without optional backup accelerator sensor] Engine runs at 1500 min⁻¹. (Speed setting can be changed).</p> <p>[With optional backup accelerator sensor] Select backup accelerator sensor: No limitation If backup sensor fails, engine runs at 1500 min⁻¹. (Speed setting can be changed).</p>	Correct failure.	Default to enable	5

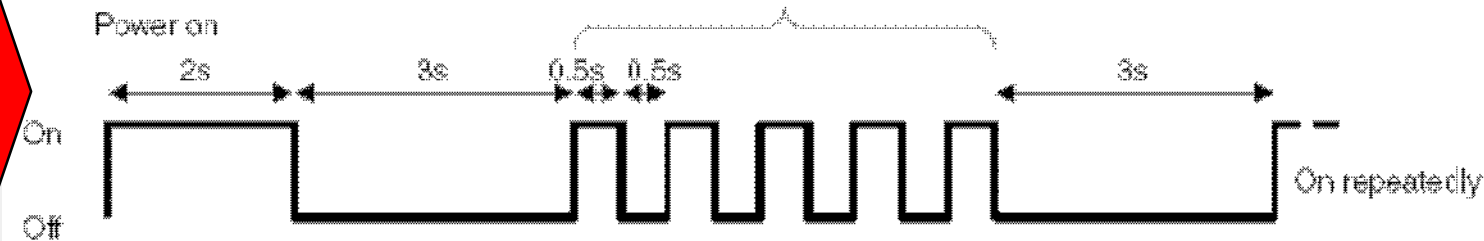
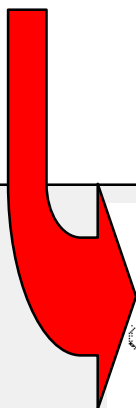



YANMAR

TNV Tier 3 Technology

Service tool and
diagnostics



Customer Panel

Blink Engine Trouble Lamp

Service tool



Indicate
Trouble Group

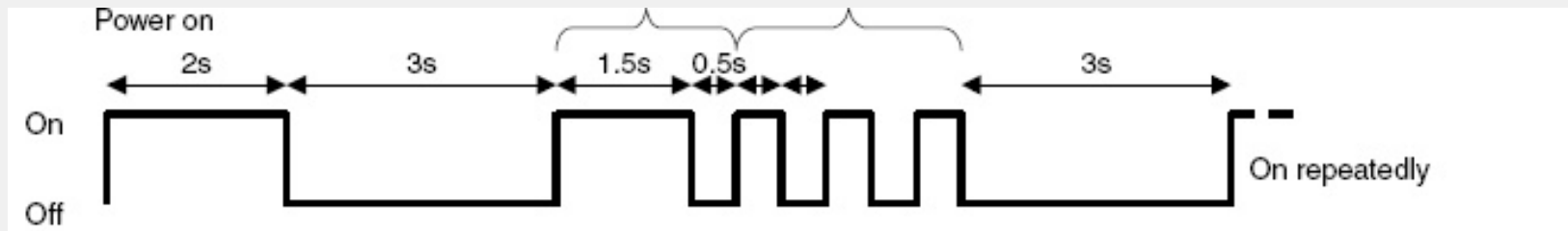

Please explain what kind of failure is indicated?



YANMAR

TNV Tier 3 Technology

Service tool and
diagnostics



Service tool

Diagnostic & monitoring software

[Configuration]

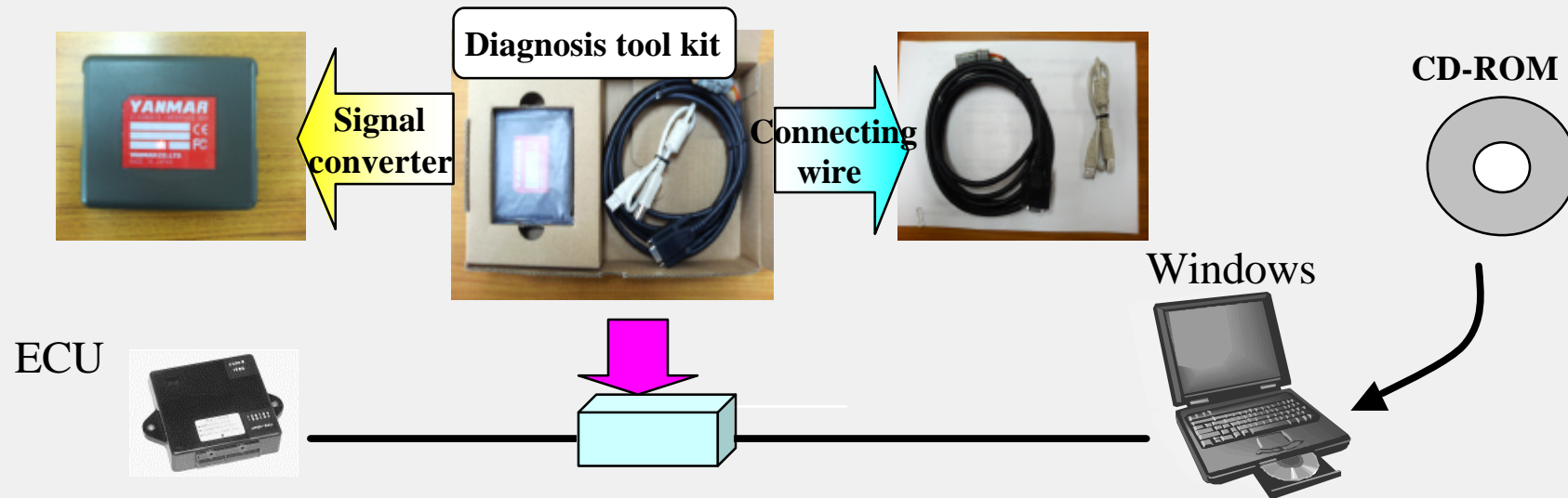



YANMAR

TNV Tier 3 Technology

Service tool and diagnostics

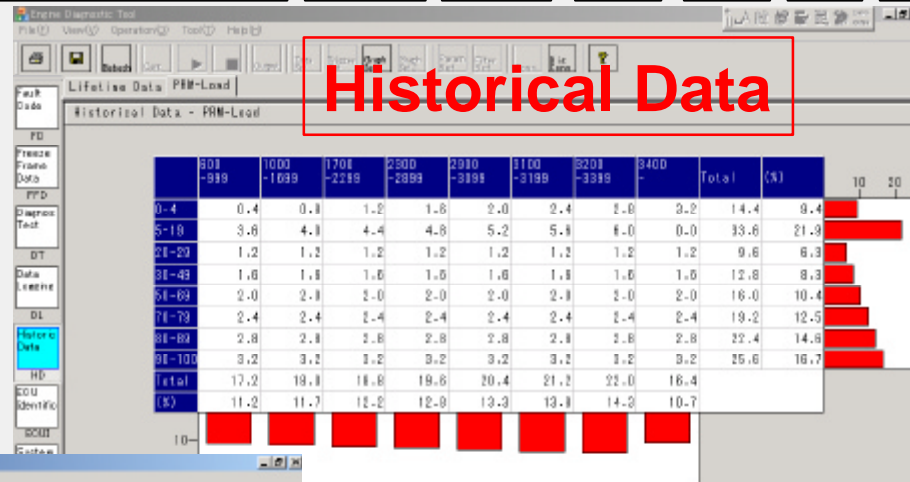

Historical Data

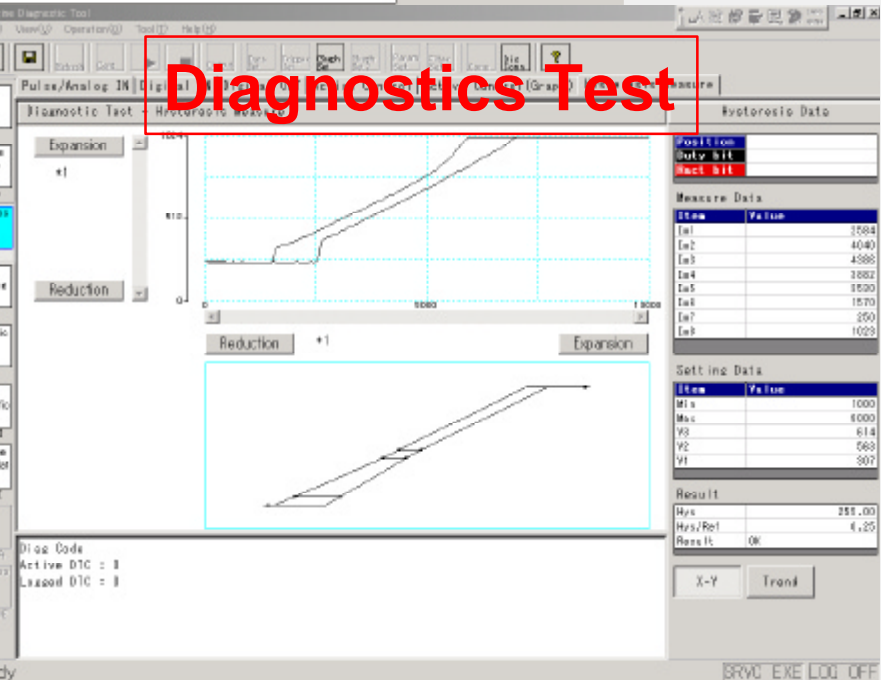
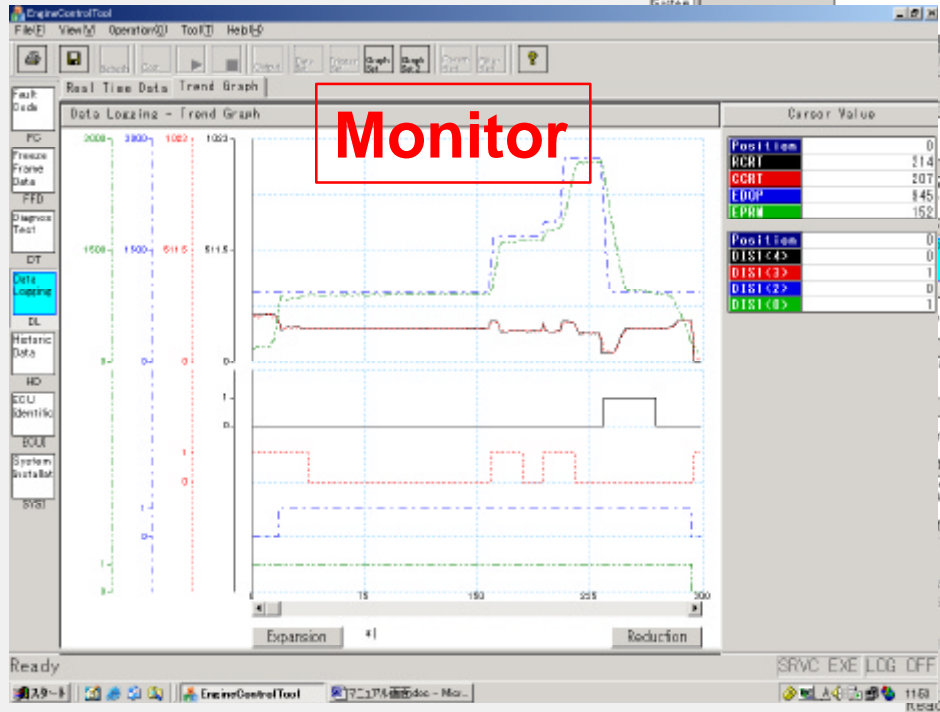



YANMAR

TNV Tier 3 Technology

Service tool and
diagnostics

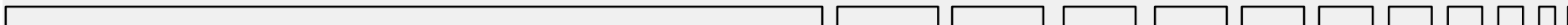

Image	Name	Abbreviation	Description
System Information SI	System Information	SI	System details (Engine / FIE / ECU)
Fault Code FC	Fault Code	FC	Trouble data
Freeze Frame Data FFD	Freeze Frame Data	FFD	Data before & after failure
Diagnosis Test DT	Diagnostic Test	DT	System check
Data Logging DL	Data Logging	DL	Analysis of engine trouble on operation
Historic Data HD	Historical Data	HD	Information of engine operation and maintenance
ECU Identification ECUI	ECU Identification	ECU_I	ECU system / ECU ID information
System Installation SYSI	System Installation	SYS_I	Engine setting and repair after installation



TNV Tier 3 Technology

What to do with the indicated failures?

Indicated failure (=DTC or flash pattern)

DTC detection conditions

- Operation condition required system setting.
- Failure condition system / failure condition which causes the fault.
- Test time minimum time needed to activate DTC
- Flash pattern number of flashes indicated

- Check point which parts / item to check



TNV Tier 3 Technology

What to do with the indicated failures?

Fault handling

- On-error mode Engine running mode when failure is active.
as-is / restricted / stop
- Limited operation described how operation is restricted
- Fail release which setting is required to release the failure.



TNV Tier 3 Technology

Indicated failure P0122/4

Low voltage for accelerator sensor

■ DTC Detection Conditions

		Check points
Precondition	Key switch ON.	Accelerator sensor Harness
Error condition(s)	Sensor voltage 0.2 [V] or lower.	
Test time	0.5 [s]	
Flashing pattern of failure indicator	Five flashes.	

■ Error Handling

	Spare Accelerator Sensor Function	
	Unavailable	Available
On-error mode	[Run Under Restrictions]: The engine continues to run at a constant speed.	[Run As Is]: The engine continues to run using the spare accelerator sensor instead.
Limited operation	Yes: The target speed is set to the "on-error target speed (standard value: 1500[min^{-1}])" or "pre-error target speed".	No.
Fail release	Yes: This error is reset when the voltage value falls within the normal range (0.2 to 4.0[V]) continuously for 0.5 [s].	Yes: This error is reset when the voltage value falls within the normal range (0.2 to 4.0[V]) continuously for 0.5 [s].
Limited operation release	Yes: The restrictions are reset when the error is reset.	No.
Remarks		



TNV Tier 3 Technology

Indicated failure P0122/4

Low voltage for accelerator sensor

Possible causes

- Accelerator sensor faulty
- Accelerator sensor signal wires disconnected or grounded.
- Input voltage (5V) signal disconnected or grounded
- Ground wire short cuts to power supply

Check method

- Check accelerator sensor function (resistance value /continuity)
- Check accelerator sensor connection (disconnected or shortcut)
- Check E38 pin (disconnected or grounded)
- Check E28 pin (power supplied to pin)



YANMAR

TNV Tier 3 Technology

troubleshooting

Indicated failure P0122/4

Low voltage for accelerator sensor

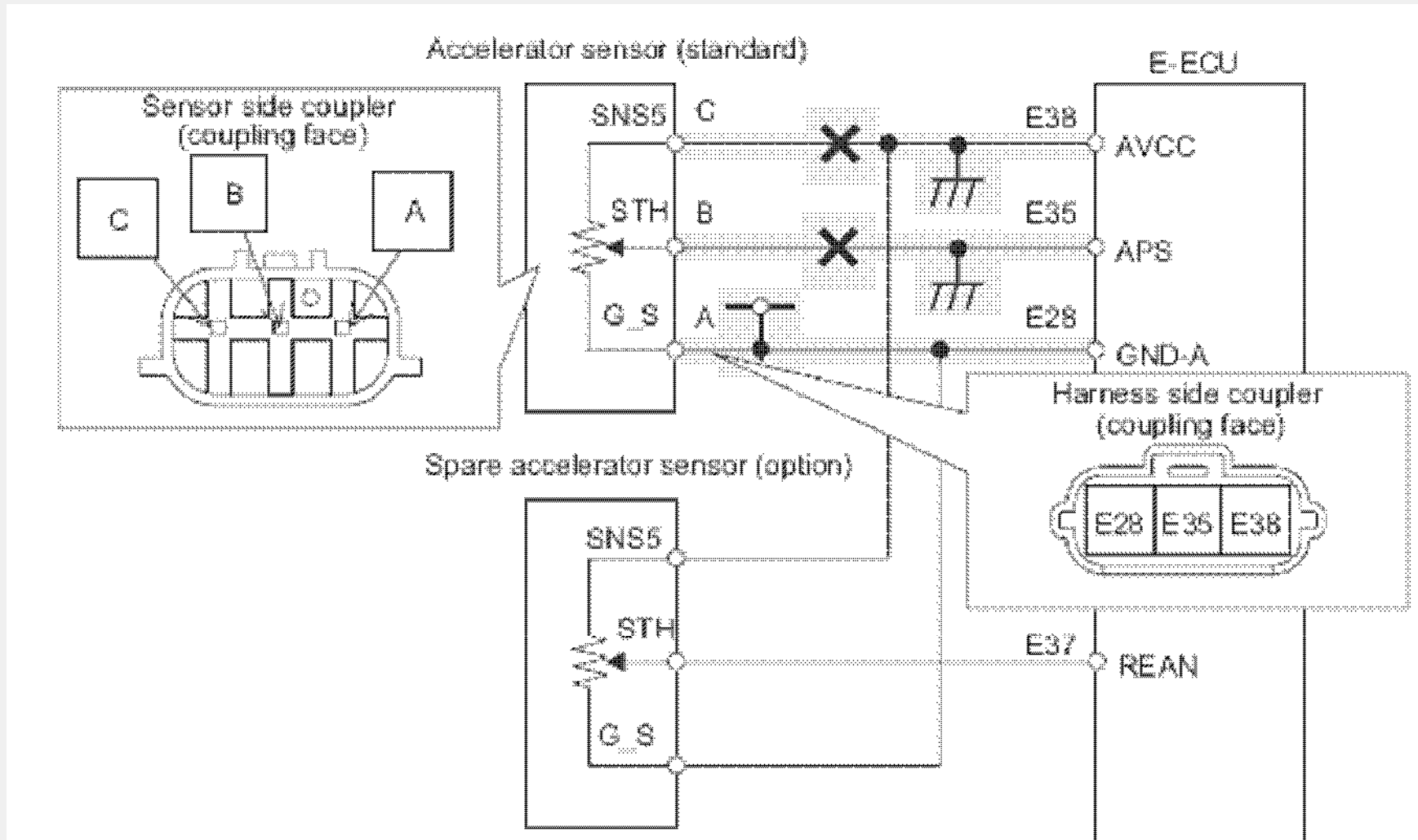



YANMAR

TNV Tier 3 Technology

troubleshooting

Indicated failure P117/4

Low voltage for CW sensor

Indicated failure P0562/1

Low power supply for ECU